

Freedom from vibration and correct alignment are the two main points to be considered when installing Gearmotors. Attention to these points will prolong the life and efficiency of the entire drive.

The shafts of the prime mover, unit and driven equipment, should be in as perfect alignment as possible. Misaligned shafts impose abnormal stress on bearings and couplings, leading to excessive wear and possibly early failure. Vibration accelerates bearing and gear wear, resulting in noisy operation. Alignment can be maintained and vibration eliminated, by mounting the drive on rigid foundations of adequate proportions and dowelling the units in position.

Fenaflex couplings are recommended when the shaft alignment cannot be assured and also when protection from peak and vibratory torques is desirable. After installation, regular inspection should be carried out to check the tightness of the holding down bolts and also the accuracy of alignment.

**BREATHERS/MOUNTING POSITIONS**

Sizes 860,801 and 861 are supplied for operation without breathers.

Sizes 802 to 863 are supplied for operation with breathers. To prevent leakage during transit these units are fitted with blanking plugs. It is essential that when the unit is in its operating position the relevant blanking plug is removed and replaced by the breather plug (supplied) in the position indicated on the installation leaflet.

Sizes 864 to 868 are supplied for operation with a breather but are despatched without oil.

**LUBRICANT CAPACITY (LITRES)**

Mounting Position	860		801		861		802		862		803		863		864		865		866		867		868	
	Double	Triple	Double	Triple	Double	Triple	Double	Triple	Double	Triple	Double	Triple	Double	Triple	Double	Triple	Double	Triple	Double	Triple	Double	Triple	Double	Triple
B3/B5	0.7	0.7	0.8	0.7	0.8	0.7	1.5	1.3	1.5	1.3	2.0	1.9	2.6	2.3	3.7	3.4	10.5	11.5	11	11	17	17	24	24
B7	0.7	0.7	0.8	0.7	0.8	0.7	1.8	1.6	1.8	1.6	2.0	1.8	3.1	2.9	6.2	6.0	12.0	11.5	22	23	31	33	49	50
B6	0.7	0.7	0.8	0.8	0.8	0.8	1.6	1.5	1.6	1.5	1.8	1.7	2.8	2.6	5.4	5.8	12.0	11.5	22	23	31	33	49	50
B8	0.7	0.7	0.8	0.8	0.8	0.8	1.9	1.9	1.9	1.9	2.1	2.1	3.3	3.3	7.3	7.9	12.0	11.5	19	20	28	30	41	43
V1/V5	1.0	1.0	1.5	1.4	1.5	1.4	1.9	1.9	1.9	1.9	2.1	1.9	3.2	2.9	6.4	6.4	16.8	16.8	32	32	47	47	72	72
V3/V6	1.0	1.1	1.5	1.5	1.5	1.5	2.7	2.5	2.7	2.5	2.9	2.7	4.9	4.7	9.1	9.3	16.4	16.5	26	27	38	40	65	67

**MOUNTING POSITIONS**

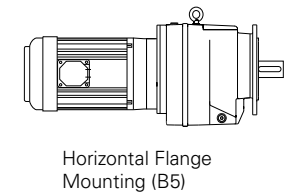
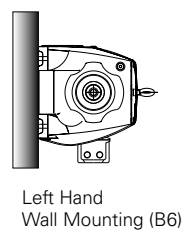
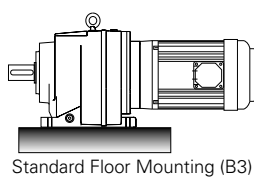
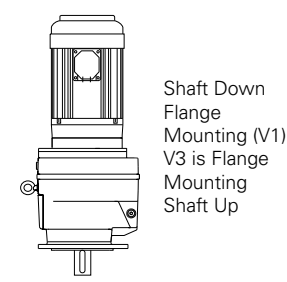
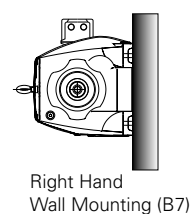
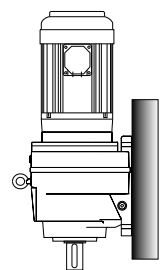
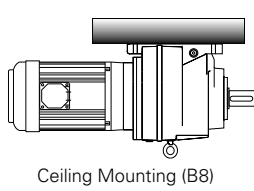

It is essential that when the unit is in its operating position the relevant blanking plug is removed and replaced by the breather plug (supplied) in the position indicated on the installation leaflet.

**LUBRICATION**

**Lubrication Change Period**

Sizes 860, 801 and 861 are lubricated for life, all other sizes of the Series M will require oil changes. Mineral oils @ 10,000 hours and synthetic oils at 20,000 hours.

**Gearmotors and Reducers**

**Sizes 860 to 863**

Motorised and Reducer types of sizes 860 to 863 are supplied ready filled with the appropriate amount of lubricant for the mounting position identified in the original order. (If the unit is to be mounted in a different position to that originally intended then the amount of lubricant in the unit will require amending - see table below for required quantities).

**Gearmotors and Reducers**

**Sizes 864 to 868**

Motorised and Reducer types of sizes 864 to 868 are despatched without oil for the customer to fill on site once installed. The different mounting positions are indicated with the appropriate oil fill quantities. The units have several oil fill and drain plugs to cater for all mounting positions. A list of approved lubricants is supplied in the table below. Sizes 864 to 868 require an oil change at 10,000 hours mineral oil, 20,000 hours synthetic oil. The tables below give the oil capacities for those units that require filling. **The mounting position should always be specified on ordering.**

**OIL CHANGE INTERVALS**

Mineral oil – 10,000 hours

Synthetic oil – 20,000 hours

**LUBRICANT TYPE TEMPERATURE RANGE**

ISO Viscosity	Ambient Temperature °C			
	-5°C to 20°C	-30°C to 20°C	0°C to 35°C	20°C to 50°C
EP Mineral Oil	220	-	320	460
Synthetic Oil	-	220	220	320

**RECOMMENDED OIL GRADES**

Supplier	Mineral Oils Containing EP Additives	Synthetic Lubricants Polyalphaolefin based
BP	Energol GR-XP	Energol EPX
Castrol	Alpha SP	Alphasyn EP or T
Esso	Spartan EP	Spartan Synthetic EP
Fuchs	Renogear V	Renogear SG
Mobil	Mobilgear 600	Mobilgear SHC
Shell	Omala	Omala HD
Texaco	Meropa	Pinnacle EP



All geared motors are identified by an eight digit code for a unit with a standard electric motor, if a different motor type is required a ninth digit is added to the end of the normal code. These codes should be included on all enquiries, correspondence and orders.

The code is made up as follows:-

**FIRST THREE DIGITS:** Gearmotor type and size. Select from the tables on pages 144-155.

**FOURTH DIGIT:** Type of assembly required

**A:** Foot mounted motorised

**B:** Flange mounted motorised

**D:** Foot mounted with input assembly

**E:** Flange mounted with input assembly

**G:** Foot mounted - unmotorised

**H:** Flange mounted - unmotorised

**FIFTH/SIXTH DIGIT:** Gear ratio code

- Assemblies A and B use complete eight digit code obtained directly from selection tables. Exact gear ratios can be found on page 168.
- For selection and specification for D, E, G and H assemblies consult Authorised Distributor

**SEVENTH/EIGHTH DIGIT:** Type of drive code

- Motorised units - use complete code from selection tables with if applicable, additional ninth digit for motor type.
- Input Reducer assembly - use **00**.
- Unmotorised - units ready for motor fitting by third party use the first two digits of the motor frame size to be fitted, i.e. frame 71 use **71** for 132 frame use **13**.

**NINTH DIGIT:** Type of motor variant

Use eight digit code obtained from selection tables for required motor power and speed and then add the relevant letter code from table opposite of the motor variant required.

### ELECTRIC MOTOR VARIANTS

All variants of standard IEC motors can be fitted to Fenner Gearmotors, Series M is also capable of accepting NEMA motor variants as well. Examples of some of the variants and their ninth digit code letter are:-

CODE	MOTOR TYPE
A	Anti-condensation heaters fitted
B	Backstop Fitted
C	Cast Iron motor
D	Brook Motor Fitted
E	Fitted with Encoder
F	Flameproof motor
G	Fitted with Oil seal
H	Class H Insulation
I	IP65 enclosure
J	Inverter-motor
K	Fitted with Tacho-generator
L	Clutch/Brake unit Fitted
M	Brake motor
N	Brake motor with Hand Release
P	Premium Efficiency Motor Fitted (EFF1)
Q	Refer to Original Quote - Special
R	Fitted with Brook ARGUS Cast Iron motor
S	Single Phase motor
T	Fitted with Thermistors
V	Special Voltage
W	WIMES Spec motor (Water Industry)
X	Fitted with Variator
Z	Fitted with Force Vent unit
5	ExN Non-Sparking motor
8	Two-speed motor
9	Special Feature

Standard clutch brake modules with IEC flanges can be fitted between motor and gearhead.

Variable speed packages are available, either belt variators or mechanical disc variators.

Backstop modules are available for motor frame sizes 100 to 200.

For any of these combinations please contact your local Authorised Distributor.



### Standard Motor Specification

Conforming in performance to BS5000 and IEC34-1 in dimensions to BS4999 and IEC72-1 and 2.

Range mounting, squirrel cage, totally enclosed fan cooled design (TEFC).

### Protection

IP55, dust and hose proof.

### Insulation

Class F.

### ELECTRIC MOTORS (BS AND IEC SPECIFICATION)

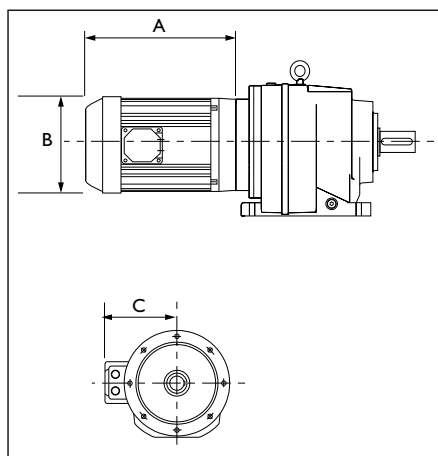

### ELECTRIC MOTOR VARIANTS

All variants of standard IEC frame motors can be fitted to the Fenner gearmotor range. They are also capable of accepting NEMA motor variants as well. Examples of some of the variants and their ninth digit code letter are:-

Code	Motor Type
A	Anti-condensation heaters fitted
B	Backstop Fitted
C	Cast Iron motor
D	Brook Motor Fitted
E	Fitted with Encoder
F	Flameproof motor
G	Fitted with Oil seal
H	Class H Insulation
I	IP65 enclosure
J	Inverter-motor
K	Fitted with Tacho-generator
L	Clutch/Brake unit Fitted
M	Brake motor
N	Brake motor with Hand Release
P	Premium Efficiency Motor Fitted (EFF1)
Q	Refer To Original Quote - Special
R	Fitted with Brook ARGUS Cast Iron motor
S	Single Phase motor
T	Fitted with Thermistors
V	Special Voltage
W	WIMES Spec motor (Water Industry)
X	Fitted with Variator
Z	Fitted with Force Vent unit
5	ExN Non-Sparking motor
8	Two-speed motor
9	Special Feature

Standard clutch brake modules with IEC flanges can be fitted between motor and gearhead. Variable speed packages are available, either belt variators or mechanical disc variators. For any of these combinations please contact your local Authorised Distributor.

### 2 POLE - 3000 REV/MIN

Motor Code *	Frame Size	Output		Speed rev/min	Dimensions (mm)			Mass kg
		kW	h.p.		A	B	C	
01	63	0.18	0.25	2755	193	124	113	7
03	63	0.25	0.33	2790	193	124	113	7
09	71	0.37	0.50	2825	218	139	121	8
10	71	0.55	0.75	2820	218	139	121	9
19	80	0.75	1.00	2810	236	157	130	12
20	80	1.10	1.50	2825	236	157	130	13
26	90S/L	1.50	2.00	2880	280	177	150	20
29	90S/L	2.20	3.00	2850	280	177	150	22
39	100L	3.00	4.00	2890	316	198	160	26
44	112M	4.00	5.50	2900	333	235	180	39
52	132S	5.50	7.50	2940	410	274	207	54
58	132S	7.50	10.00	2930	410	274	207	59
63	160MA	11.00	15.00	2920	545	330	250	134
64	160MB	15.00	20.00	2930	545	330	250	134
69	160LA	18.50	25.00	2930	545	330	250	152
77	180MA	22.00	30.00	2955	600	380	275	174

### 4 POLE - 1500 REV/MIN

Motor Code *	Frame Size	Output		Speed rev/min	Dimensions (mm)			Mass kg
		kW	h.p.		A	B	C	
02	63	0.18	0.25	1410	193	124	113	8
06	71	0.25	0.33	1420	218	139	121	9
08	71	0.37	0.50	1405	218	139	121	9
81	71	0.55	0.75	1410	250	159	111	10
16	80	0.55	0.75	1440	236	157	130	12
82	71	0.75	1.00	1410	250	159	111	10
18	80	0.75	1.00	1430	236	157	130	13
24	90S/L	1.10	1.50	1445	280	177	150	20
28	90S/L	1.50	2.00	1430	280	177	150	23
36	100L	2.20	3.00	1430	316	198	160	25
38	100L	3.00	4.00	1420	316	198	160	29
46	112M	4.00	5.50	1440	333	235	180	44
54	132S	5.50	7.50	1470	410	274	207	58
56	132M	7.50	10.00	1470	410	274	207	60
66	160MA	11.00	15.00	1450	520	330	250	134
68	160LA	15.00	20.00	1455	565	330	250	152
76	180MA	18.50	25.00	1465	590	380	275	174
78	180LA	22.00	30.00	1465	630	380	275	184
88	200L	30.00	40.00	1470	670	415	320	286
94	225S	37.00	50.00	1480	725	460	345	338
95	225M	45.00	60.00	1480	725	460	345	358
96	250MA	55.00	75.00	1475	805	512	375	535

### 6 POLE - 1000 REV/MIN

Motor Code *	Frame Size	Output		Speed rev/min	Dimensions (mm)			Mass kg
		kW	h/p		A	B	C	
05	71	0.18	0.25	910	218	139	121	9
07	71	0.25	0.33	905	218	139	121	10
12	80	0.37	0.50	935	236	157	130	12
17	80	0.55	0.75	935	236	157	130	13
23	90S/L	0.75	1.00	930	280	177	150	21
27	90S/L	1.10	1.50	935	280	177	150	23
37	100L	1.50	2.00	950	316	198	160	24
45	112M	2.20	3.00	950	333	235	180	34
53	132S	3.00	4.00	965	410	274	207	47
55	132M	4.00	5.50	965	410	274	207	56
57	132M	5.50	7.50	965	410	274	207	64
65	160M	7.50	10.00	965	520	330	250	134
67	160L	11.00	15.00	965	565	330	250	152
74	180L	15.00	20.00	970	630	380	275	184
75	200LA	18.50	25.00	980	670	415	320	286
84	200LB	22.00	30.00	975	670	415	320	286
91	225M	30.00	40.00	985	725	460	345	358
92	250M	37.00	50.00	980	805	512	375	535
93	280S	45.00	60.00	985	830	570	410	563
97	280MA	55.00	75.00	985	880	570	410	720

Dimensions A, B and C are based on the standard motor normally supplied, for details when another type of motor is required consult your local Authorised Distributor.

Starting torque, starting current and current at various voltages vary depending on the type of unit. Consult your local Authorised Distributor.

\* Last two digits of the complete eight digit ordering code from the selection tables.